

# Advanced Research Center for Beam Science - Structural Molecular Biology -

<http://www.scl.kyoto-u.ac.jp/~hata/index.html>



Prof  
HATA, Yasuo  
(D Sc)



Assoc Prof  
ITO, Yoshiaki  
(D Sc)



Assist Prof  
FUJII, Tomomi  
(D Sc)



Res  
TOCHIO, Tatsunori  
(D Sc)

## Students

OoHASHI, Hirofumi (D3)

SAKAKURA, Shusuke (D1)

MIZOTA, Hirohisa (D1)

HORIGUCHI, Daisuke (M2)

YOKOI, Koji (M2)

GODA, Yuko (M1)

## Scope of Research

The research activities in this laboratory are performed for X-ray structural analyses of biological macromolecules and the investigation of the electronic state in materials as follows: The main subjects of the biomacromolecular crystallography are crystallographic studies on the reaction mechanism of enzymes, the relationship between the multiform conformation and the functional variety of proteins, and the mechanism of thermostabilization of proteins. In the investigation of the chemical state in materials, the characteristics of the chemical bonding in the atom and molecules are investigated in detail using a newly developed X-ray spectrometer with a high-resolution in order to elucidate the property of materials. The theoretical analysis of the electronic states with DV-X $\alpha$  and WIEN2k, and the development of new typed X-ray spectrometer with ultra-high-resolution have also been carried out.

## Research Activities (Year 2005)

### Presentations

Structure and Inhibition Mode of Protein I<sup>C</sup> in Complex with Carboxypeptidase Y, Hata Y, Hayashida M, Fujii T *et al.*, XX Congress of the IUCr, 30 August.

The Structure of Carboxypeptidase Y Inhibitor I<sup>C</sup> in Complex with the Cognate Proteinase and a Novel Mode of the Proteinase-Protein Inhibitor Interaction, Hata Y, Hayashida M, Fujii T *et al.*, Pacificchem2005, 16 December.

Structure of the Carboxypeptidase Y Inhibitor I<sup>C</sup> in Complex with the Cognate Proteinase Reveals a Novel Mode of the Preteinase-Protein Inhibitor Interaction, Mima J (Kyoto University), Hayashida M, Fujii T *et al.*, J. Mol. Biol. **346**, 1323-1334 (2005).

Structure and Inhibition Mode of Protein I<sup>C</sup> in Complex with Carboxypeptidase Y, Hata Y, Hayashida M, Fujii T *et al.*, Acta Cryst. **A61** (Supplement), C190 (2005).

### Grants

Hata Y, Structural Analyses of Gene-products Involved in Protein Structure Formation, Protein 3000 Project, 1 April 2002 - 31 March 2007.

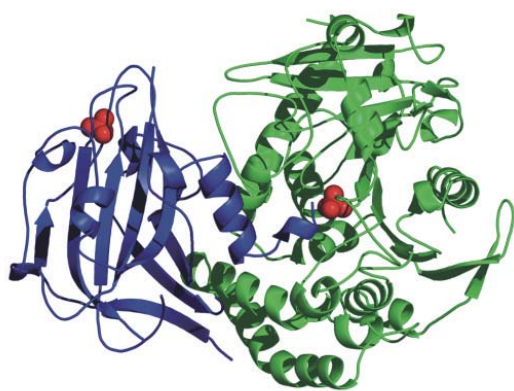
Sanjoh A (Protein Wave Corporation), Hata Y *et al.*, Studies and Developments on Practical Use of Devices for Growth of Protein Crystals Suitable for Ultra-high Resolution X-ray Analysis, Grant for Support of Studies and Developments by Cooperation of Industry, Academic and Public, Kyoto Sangyo 21 Foundation, 1 April 2004 - 31 March 2006.

Ito Y, Development of Basic Technologies for New Functional Particle Materials, Kyoto Prefecture Collaboration of Regional Entities for the Advancement of Technological Excellence, JST, 2004 - 2008.

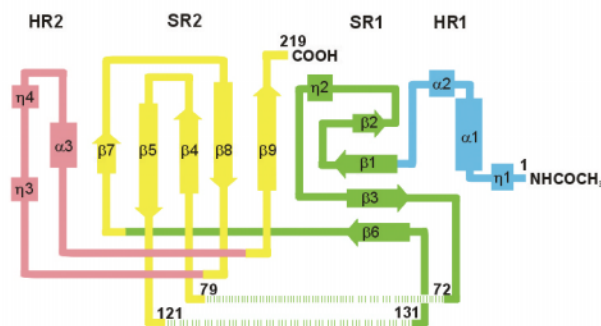
## Crystal Structure of the Inhibitor I<sup>C</sup> in Complex with Carboxypeptidase Y

The proteinous proteinase inhibitor I<sup>C</sup>, which exists in the cytoplasm of the yeast *Saccharomyces cerevisiae*, specifically forms the 1:1 complex with and then inhibits carboxypeptidase Y (CPY) which is the vacuolar serine carboxypeptidase. The inhibitor belongs to the phosphatidylethanolamine-binding protein (PEBP) family. In order to reveal the inhibitory mode of I<sup>C</sup> against CPY, we determined the 2.7Å crystal structure of the I<sup>C</sup>-CPY complex by the MR method of X-ray crystallography. This represents the first structure of a natural serine carboxypeptidase inhibitor complexed with the cognate proteinase and also that of a PEBP member complexed with its macromolecular binding partner.

The final structure model of the I<sup>C</sup>-CPY complex contains 204 amino acid residues of I<sup>C</sup> consisting of 219 amino acid residues. Residues Lys73-Ala78 and Glu122-Ala130 of I<sup>C</sup> are excluded in the model because they are invisible in the electron density map. The overall structure of the complex is a compact ellipsoidal structure (Fig1). The structure of the complex contains two binding sites of I<sup>C</sup> toward CPY: the N-terminal inhibitory reactive site and the secondary CPY-binding site, which interact with the S1 substrate-binding site of CPY and the hydrophobic surface flanked by the active site of the enzyme, respectively. The structure of I<sup>C</sup> in complex with CPY consists of one major  $\beta$ -type domain and an N-terminal helical segment (Fig2). The N-terminal segment is the helical region 1 (HR1), which is formed by one  $3_{10}$ -helix ( $\eta_1$ ) and two  $\alpha$ -helices ( $\alpha_1$ -2) and is in direct contact with CPY. The major domain is made up of three segments: the strand-rich region 1 (SR1), strand-rich region 2 (SR2), and helical region 2 (HR2). I<sup>C</sup> is also revealed to have the ligand-binding site, which is conserved among PEBPs and the putative binding site of the polar head group of phospholipid.

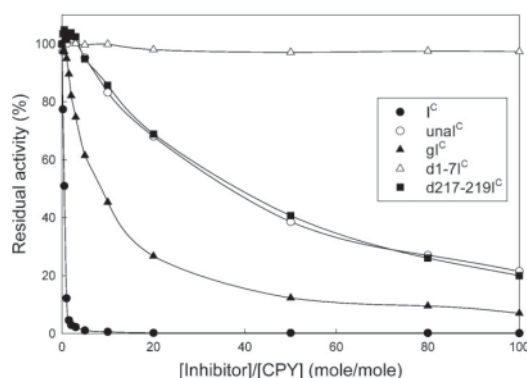


**Figure 1.** Ribbon drawing of the I<sup>C</sup>-CPY complex at 2.7 Å resolution. I<sup>C</sup> and CPY are shown in blue and green, respectively. Sulfate ions are represented by red spheres.



**Figure 2.** A topology diagram of the secondary-structure elements in I<sup>C</sup>.  $\beta$ -Strands ( $\beta_1$ -9) are represented by arrows, and  $\alpha$ -helices ( $\alpha_1$ -3) and  $3_{10}$ -helices ( $\eta_1$ -4) by rectangles.

To further clarify the proteinase-inhibition mode of I<sup>C</sup> indicated by the three-dimensional structure of the complex, we analysed the biochemical properties of various I<sup>C</sup> mutants: the N-terminal unacetylated form (unaI<sup>C</sup>), an N-terminal modified form with the substitution of Gly for the acetyl group (gI<sup>C</sup>), the N-terminal seven-residues deleted form (d1-7I<sup>C</sup>), and the unacetylated and C-terminal deleted form (d217-219I<sup>C</sup>). The inhibition of anilidase activity of CPY by the native and mutant forms of I<sup>C</sup> showed that the inhibitor constants,  $K_i$ , for unaI<sup>C</sup>, gI<sup>C</sup>, and d217-219I<sup>C</sup> were increased by 590-, 180-, and 550-fold, respectively, over that of the native and that the N-terminal deleted mutant (d1-7I<sup>C</sup>) had no detectable inhibitory activities against CPY (Fig3). These results indicate that the N-terminal acetyl group has optimal properties for the efficient inactivation of CPY and that the N-terminal seven residues of I<sup>C</sup>, designated as the N-terminal inhibitory reactive site, are absolutely essential for the inhibitory activity of I<sup>C</sup> in solution.



**Figure 3.** Stoichiometry of CPY inhibition by I<sup>C</sup> and its mutants.